

# Light weight crew rest mattresses

**CABINAIR**  
SERVICES

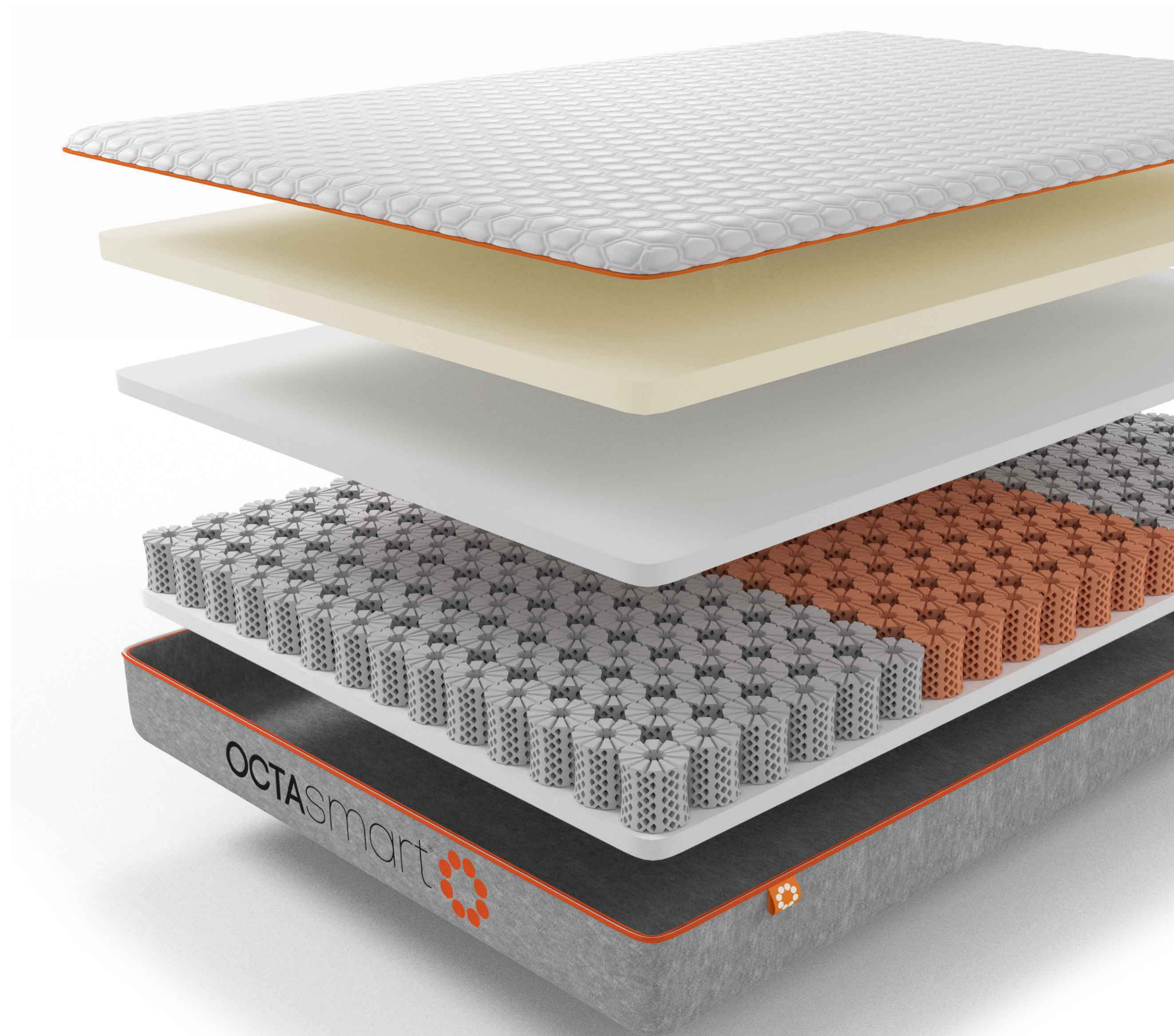

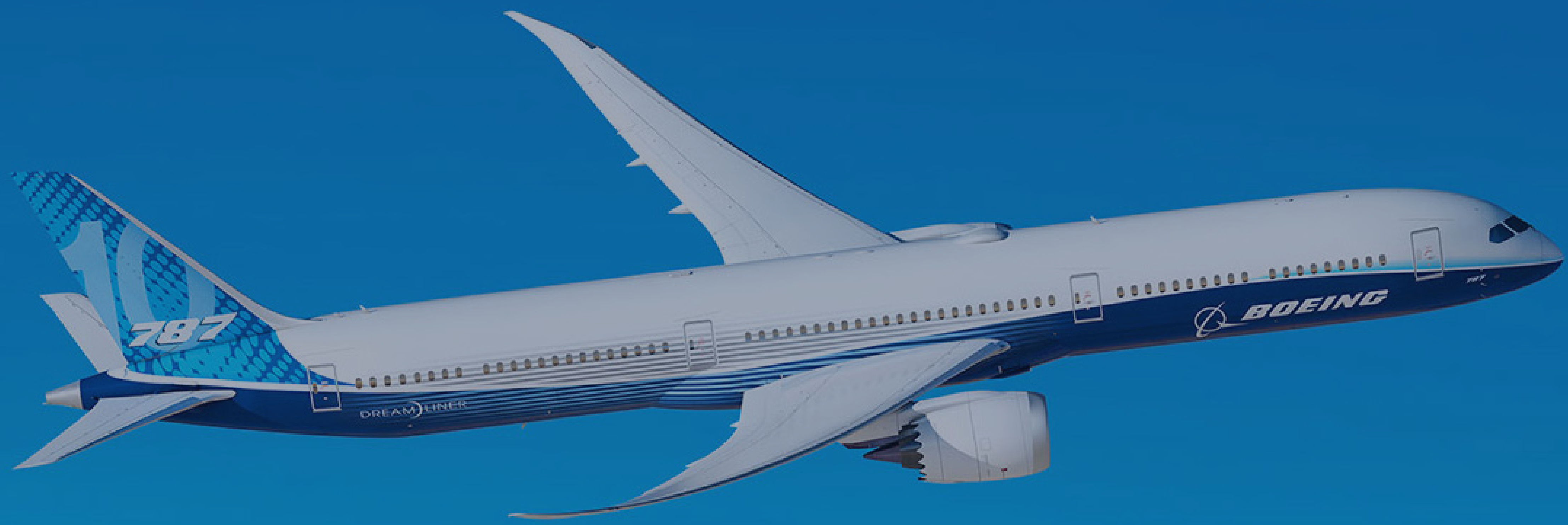

BOEING 787 DREAMLINER  
**Light weight mattresses by Cabinair Services**





# BOEING 787 DREAMLINER



**A** Mattress and miscellaneous instl-ovhd flight crew rest

**B** Mattress instl-ovhd flight attendant rest bunk aft

**C** Mattress and pad instl-ovhd flight attendant rest bunk fwd

**A**

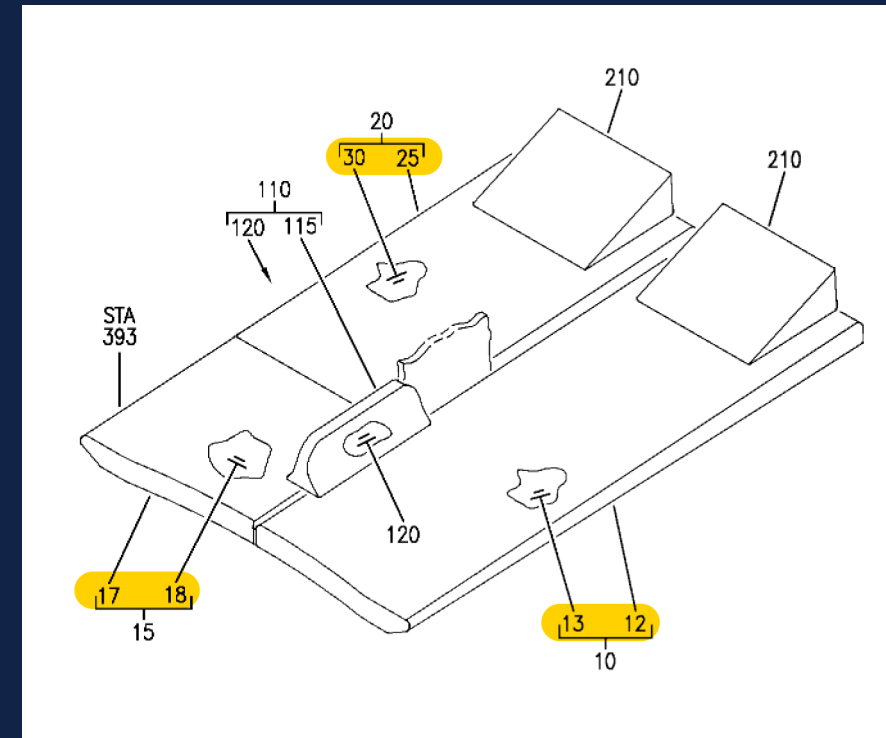

**B**

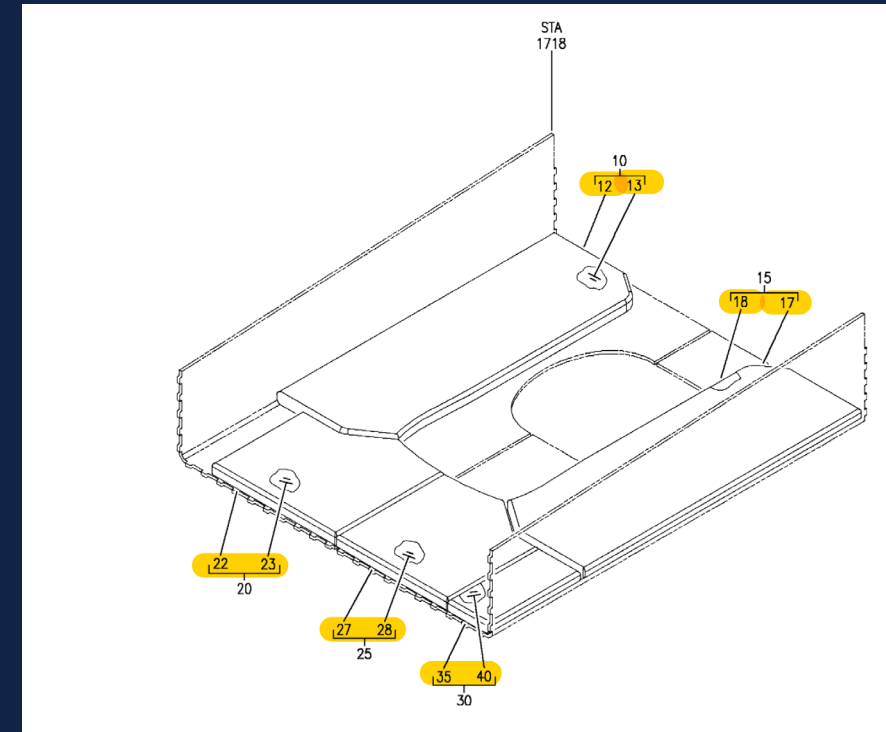

**C**

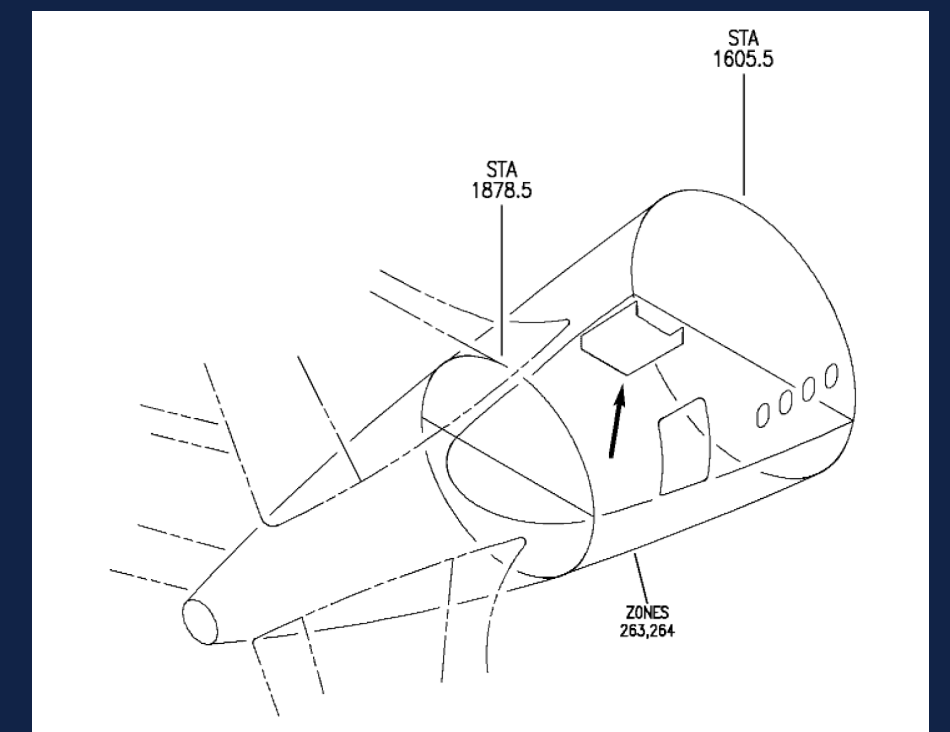
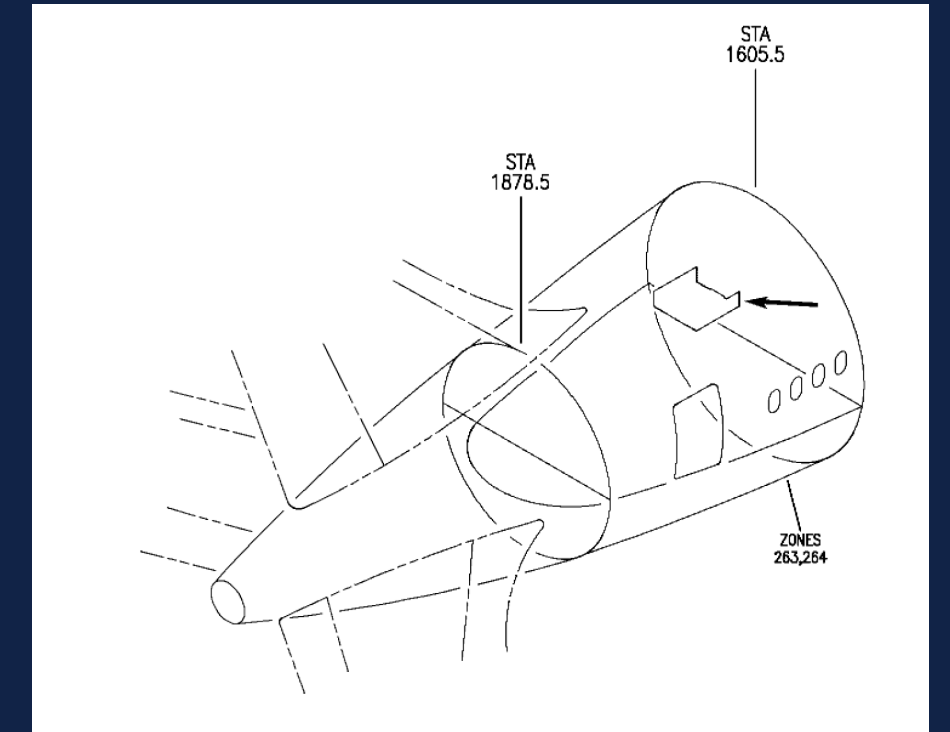
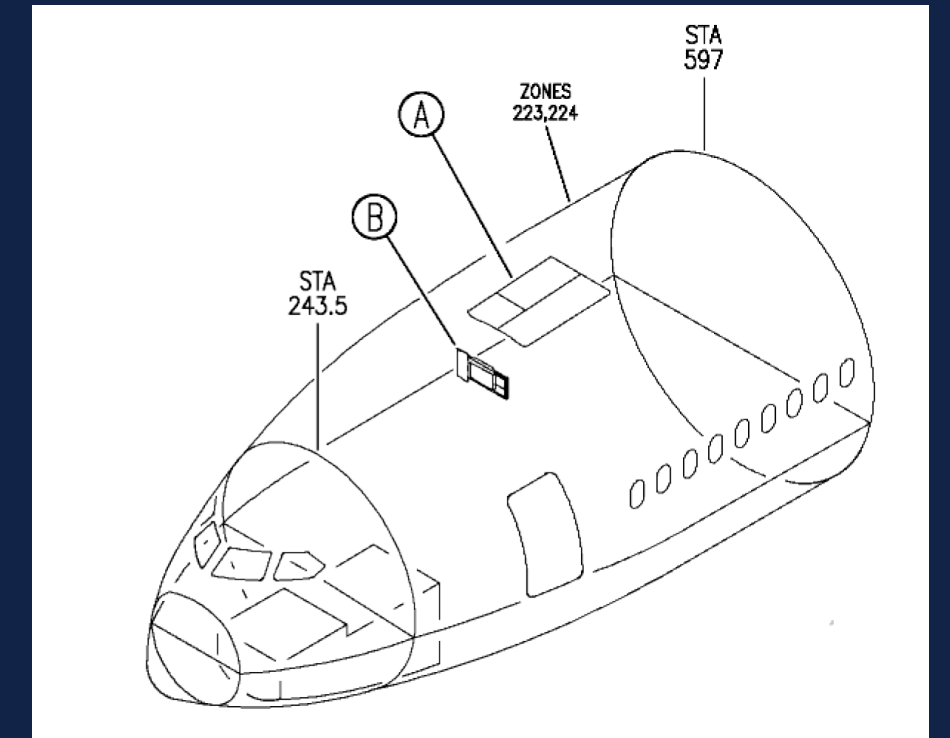
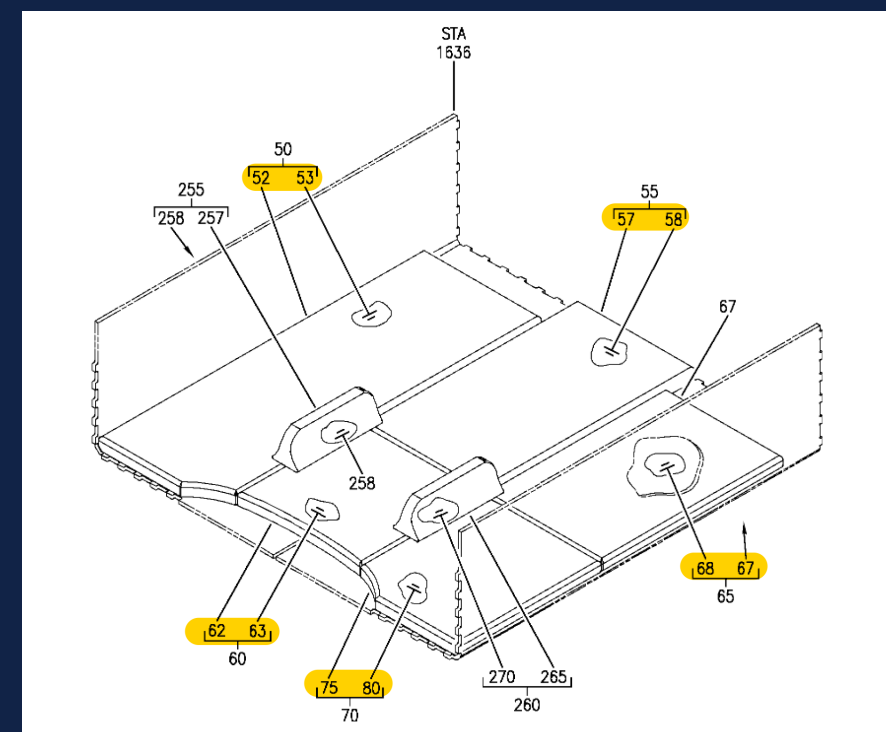



# MAIN ADVANTAGE

- ✔ Depending on the design of the set currently on the A/C the mattresses are on average 20 to 30% cheaper compared to OEM.
- ✔ Thanks to the collaboration with Manifattura Testori, we can now offer 100% Recycled and Recyclable covers to complete the assembly of the mattresses.
- ✔ It is lightweight saving approximately 9kg per aircraft thus making this an overall saving to the airline and better for the environment.
- ✔ The mattress uses less material than other market OEM mattresses, with high breathability and constant airflow. This makes for more comfort and a lower overall temperature for sleeping.
- ✔ The mattress technology is patented, therefore this cannot be duplicated by other crew mattress manufacturers.
- ✔ The first year of dry cleaning is completely free of charge.
- ✔ The Mattress Assy is assembled 100% in Italy.
- ✔ Possibility to anti bed bugs treatment, which guarantee 99% efficacy.

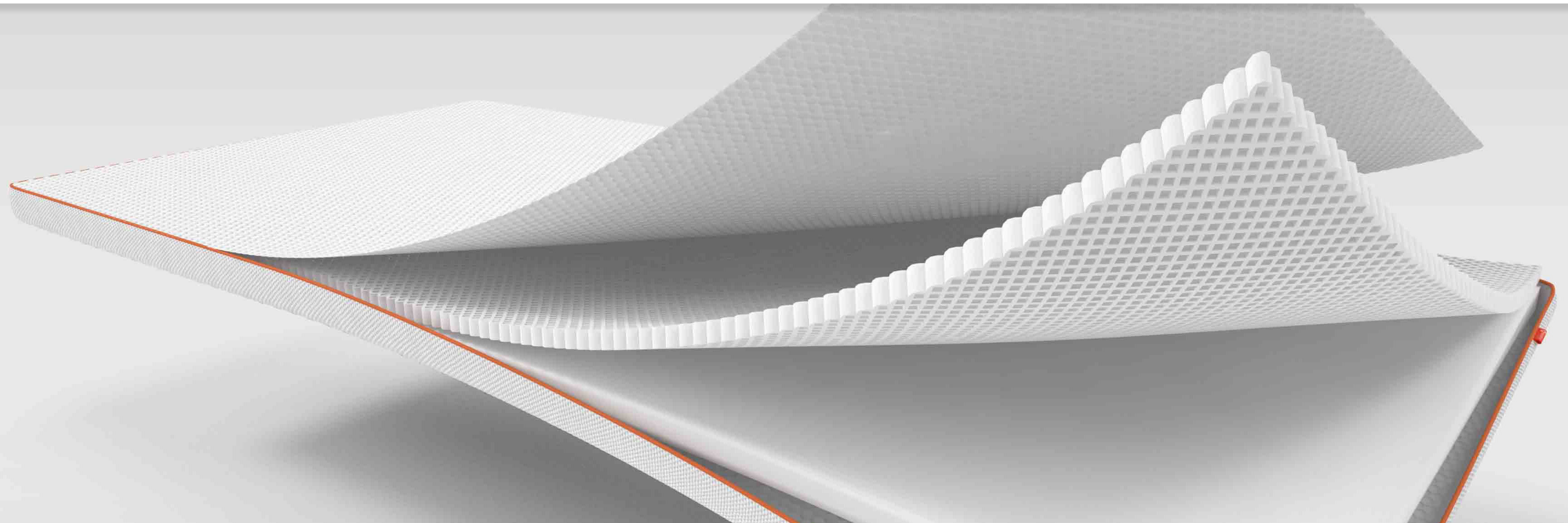



# THE OCTASPRING TECHNOLOGY



## **Aerospace technology**

Recognised as the best new comfort innovation in aerospace.



## **50% more eco-friendly**

Each Octaspring uses 50% less raw materials, and leaves 50% less eco-footprint vs foam cushions



## **Smart value**

Octaspring technology uses 50% less material in production of every spring, these savings allow us to deliver smart value for our sleep collection.



## **Proven faster, deeper, longer sleep**

An independent sleep study showed that you will fall asleep faster, sleep longer on Octaspring technology



## **Naturally 8X more breathable**

Octaspring is naturally 8x more breathable, which makes sleeping on OCTAsmart 3°C cooler.



## **8X better pressure relief**

Individually placed Octaspring springs offer up to 8X better pressure distribution vs standard foam.



## **Unique zoned support**

Different firmness zones are cleverly designed with your body in mind. Another unique benefit of Octaspring



## **Mass customisation**

Octaspring technology offers limitless possibilities for customisation.



# NEW ECO-QUALITY AVAILABLE

Thanks to the collaboration with Manifattura Testori, all mattresses covers and fire protection layer will be produced with Recycled polyester or wool yarn.

## Polyester Covers eco-advantage

- ✔ 60% Energy saving in production
- ✔ 45% Lower CO2 emission in production
- ✔ 90% Water Saving in production

## Wool Covers eco-advantage

- ✔ 47% Energy saving in production
- ✔ 47% Lower CO2 emission in production
- ✔ 61% Water Saving in production

**Testori** | Tessuti made in Italy dal 1904.





# THE OCTASPRING TECHNOLOGY

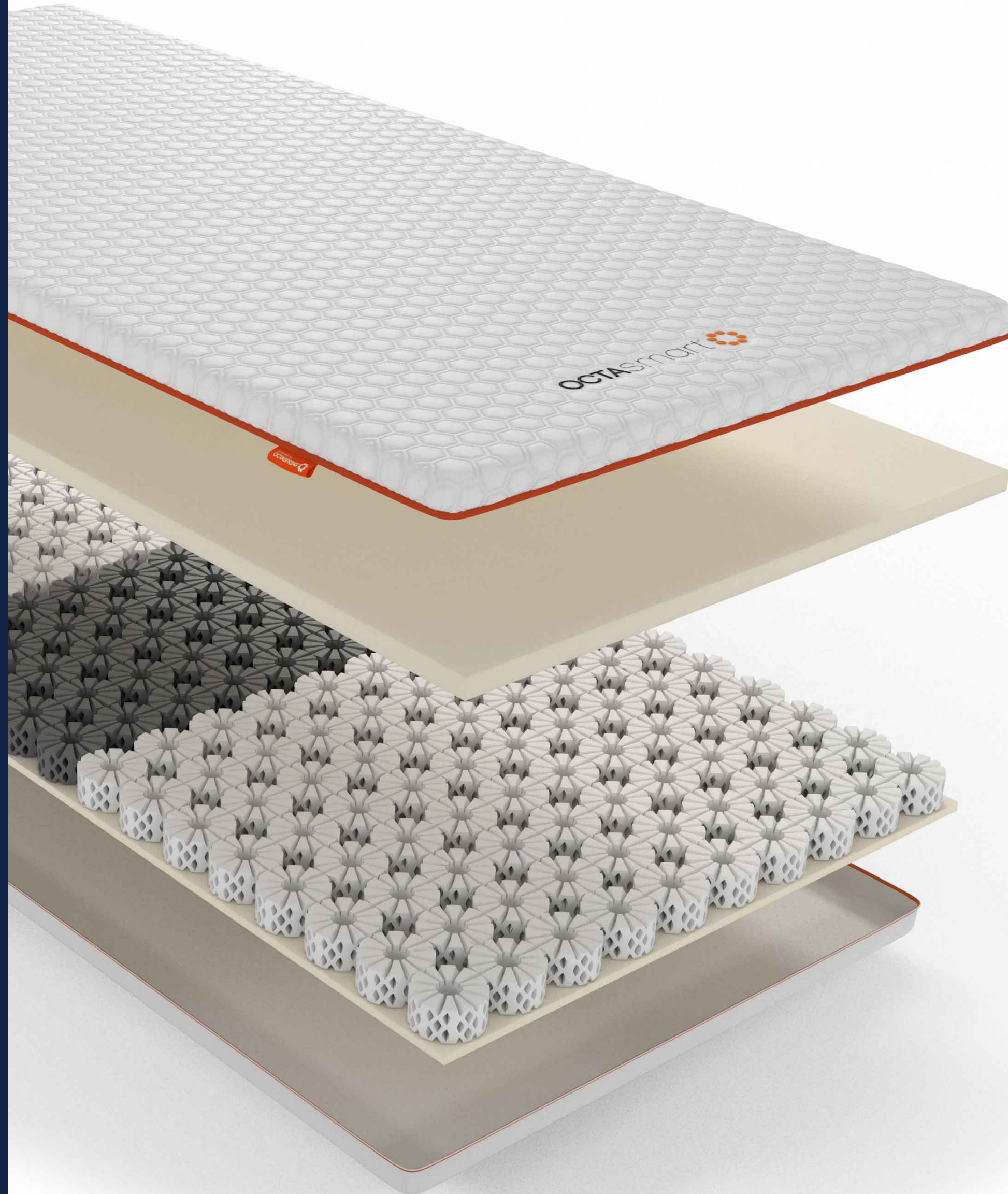

## ✔ **SMART COMFORT**

Powered by multi-award winning Octaspring technology, our topper delivers 3-dimensional support, through the ability to perfectly adapt to every inch of your body, cradling it and providing a new level of comfort.

## ✔ **ERGONOMIC ZONING**

The 3 smart body zones help create better support for your back, with more support created for your hips and shoulders which allows your spine to comfortably take its natural shape.

## ✔ **30% LIGHTER**

As we use up to 50% less material in production of every Octaspring spring. Our Octaspring technology is lighter - creating less CO<sub>2</sub>, when manufacturing our cabin crew mattresses. We can achieve up to 150g weight saving per mattress

## ✔ **NATURALLY 8X MORE BREATHABLE**

Our patented OCTAvent air system makes your cabin crew mattress naturally 8x more breathable, which cools your bed temperature by 3°C. It provides a constant airflow – body movements push warm, humid air out of the specially designed sides of the Octaspring springs, drawing fresh air back in.





# GREENER MOBILITY



Each individual Octaspring foam spring uses roughly half of the weight of equivalent foam block, resulting up to 30% weight saving in finished seat cushion (up to 150 g in Economy and up to 800 g in Business Class seats). Using Octaspring technology in cabin crew bunk beds brings additional savings of up to 2,5 kg per bed

Newly designed seat cushions can achieve higher returns when the technology is integrated during initial seat design. Older model seat cushions are often less optimized, resulting in even higher weight savings when refurbished with Octaspring technology

Our calculations have found that weight savings through Octaspring technology can reduce fuel consumption and depending on aircraft model and cabin layout Octaspring can save on fuel up to US\$5000/aircraft/year on long haul routes in addition to cutting CO2 emissions





# GREENER MOBILITY



ECONOMY CLASS



BUSINESS CLASS



FIRST CLASS



CABIN CREW MATTRESS

## 31% LESS RAW MATERIAL

We use 50% less material in the production of every Octaspring spring, which results in up to 31% less raw material used in every seat cushion.

## LOWER WEIGHT

Weight savings of up to 150g in Economy and up to 800g in Business Class seats can result in up to 32 tons of weight savings per plane per year.

## -14,825L FUEL CONSUMPTION

Our calculations have found that weight savings through Octaspring technology can reduce fuel consumption by up to 14,825L per aircraft per year

## 46T LOWER CO2 EMISSIONS

Weight savings created by Octaspring technology have the potential to deliver 46tons lower CO2 emissions per plane per year.





# AWARD WINNING AEROSPACE TECHNOLOGY

## AEROSPACE AWARDS

In 2017 Octaspring, in association with Airbus, Stelia Aerospace and Boxmark won the Crystal Cabin Award, the highest award for aircraft interior innovation. This was quickly followed by The Apex Awards, Best Passenger Comfort Innovation recognising the best innovations in passenger experience.

## DESIGN & CONSUMER AWARDS

Octaspring technology has won many awards for design and technology. The IF Technology award is the seal of approval for excellence and quality. Designpreis Deutschland identifies unique design trends and the Interior Innovation Awards honour products with iconic design





# DEVELOPED IN PARTNERSHIP WITH VANEMA

With a vision to revolutionise aerospace comfort innovation worldwide, our experts at Vanema are always looking to reimagine the next generation of Octaspring technology for the future of on-board comfort, with the retro-fit aviation industry a top priority in enhancing economy seats in new and existing aircraft.

**Partnering with Cabinar Services, the industry leaders in aircraft cabin interior refurbishments, our mission is to reinvigorate Economy passenger air craft seats with Octaspring technology across the retro-fit market on a global scale.**

Working closely in collaboration with the engineers at Cabinar Services, we combined our extensive expertise to develop a design that offered the same dynamic level of support with a flexible formula easily adaptable to a range of aircraft seat models. Our patented award-winning Octaspring aerospace technology has become synonymous with sustainability and thanks to its innovative qualities, not only infuses our new retro-fit market model with the same sumptuous support but with sustainable benefits that will transform the nature of cabin interior refurbishments.

With planes undergoing refurbishments every 5-8 years, the nature of our Octaspring open spring structure is essential in delivering a sustainable solution, with technology that uses 50% less raw materials. As a result, the seat itself is 30% lighter and therefore produces half the amount of emissions than that of regular seat alternatives. Every retro-fitted Octaspring Cabinar Services seat contributes to a phenomenal overall weight-saving, helping to reduce fuel consumption, saving up to US\$5000 per aircraft per year on long haul routes, in addition to cutting CO2 emissions by 46 tonnes.

Using less material to create the same contouring comfort means that we can offer Retro-fit solutions with Cabinar Services for a price that doesn't cost the earth in more ways the one, allowing airlines to affordably enhance the Economy class comfort experience and protect the planet. Additionally, this new comfort collaboration offers airlines an update to their existing aircraft that delivers advanced air ventilation thanks to Octaspring's 8 x naturally more breathable structure that also delivers 3-dimensional point adaptive body zoned comfort customising to each passenger's unique body shape and weight, taking passenger comfort to a whole new level.

The solution has already received required Flammability approvals and thanks to our EASA 21J and EASA 21G approval in house we can provide to the airline the full package.





# DEVELOPED IN PARTNERSHIP WITH MANIFATTURA TESTORI

Founded in 1904 near Milan, Manifattura Testori has brought to life many ambitious and important projects, taking Italian taste and craftsmanship around the world right from the beginning of the 20th century. In the historical site of Novate Milanese, still today the operating headquarter of the Company, in the first decades of the past century, production concentrated on fabrics for interior furnishings and, later, on those for railways and cruise ships. Then, between the 1950s and 1960s, Testori began working also with the aviation sector, firstly with Air France and Alitalia and later with the other world leading airlines.

Manifattura Testori cooperates with the Supply chain aiming to build an “Industry Partnership” following the principles of Eco-Design:

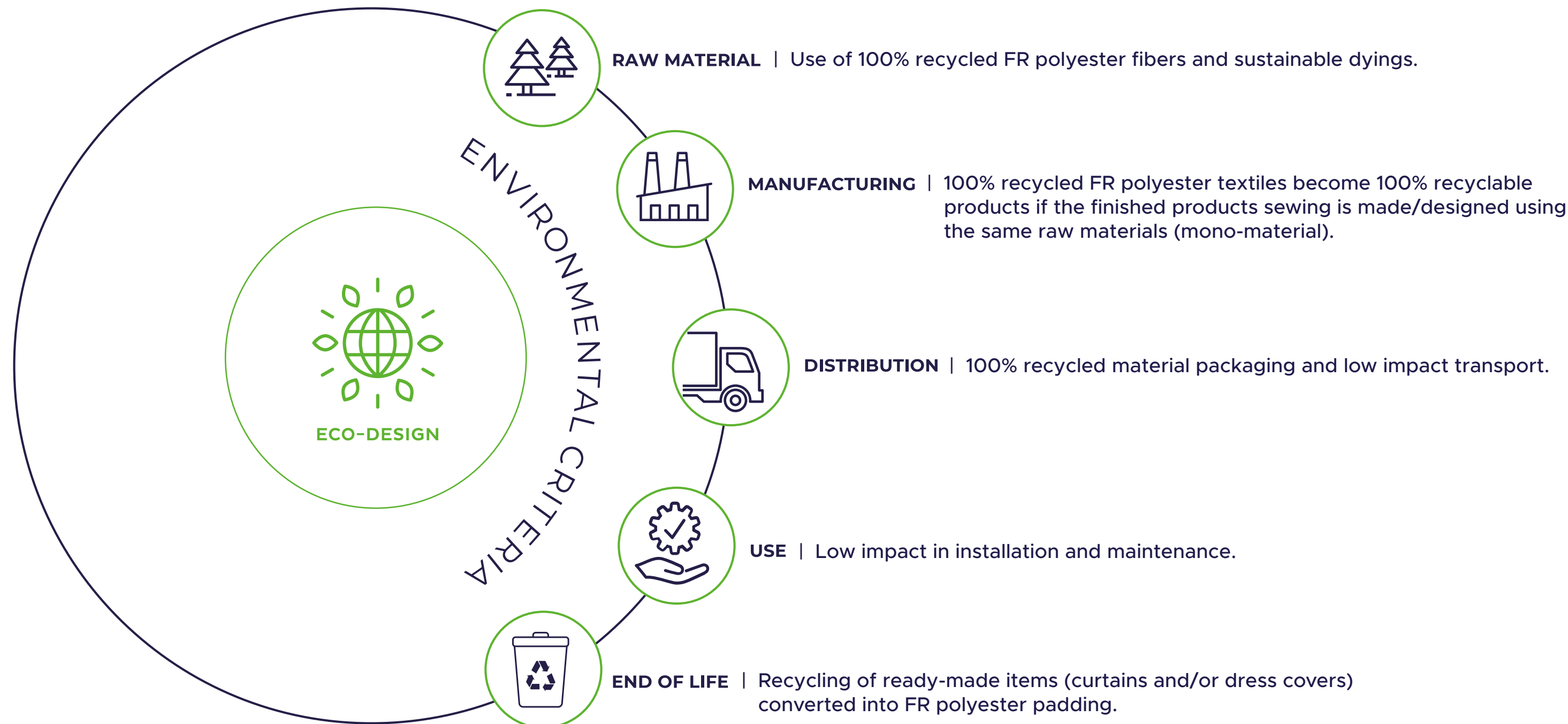



## CONTACT

**Mirko Giacobelli**

*Commercial Director*

**T: +44 1462 413081**

**M: +44 7796 694499**

**E: [mirko@satto.aero](mailto:mirko@satto.aero)**

**W: [www.satto.aero](http://www.satto.aero)**

SATTO® Solutions /  
Cabinair Services /  
SATTO® Repair Center USA

**CABINAIR**  
SERVICES

